

PENDOTECH® UV-VIS-NIR PHOTOMETER FOR UV ABSORBANCE AND TURBIDITY MEASUREMENTS USER'S MANUAL

Disclaimer

All rights reserved. No part of this publication may be reproduced, stored in an electronic retrieval system, or transmitted, in any form or by any means, whether electronic, mechanical, by photocopying, or otherwise, without the written consent of PendoTECH.

The information in this *User Guide* is believed to be accurate and reliable for use and operation of the monitor, however, PendoTECH assumes no responsibility for the use of this product except for what is covered in the Limited Warranty and Terms and Condition of Sale.









NOTE: "NOTE" is used to notify the user of installation or operation information which is important but not hazard related.

Safety Guidelines

	<p>Warning potential shock hazard. Do not submerge this product. Protect the product before cleaning with any liquids by covering openings that expose the internal components.</p>
---	---

Each prospective user must test the measurement unit for its proposed application to determine its suitability for the purpose intended prior to incorporating the sensor to any process or application. The measurement unit is not intended for use as a component in life support. The sensor is not designed for any application in which the failure of the product could result in property damage, personal injury, or death. Proper safeguards must be put into place for the process in which the unit is used.

This device has left our facility after careful testing of all the photometer's functions and safety features. The functioning and operational safety of the product can only be ensured if the user observes the usual safety precautions as well as the specific safety guidelines stated in these operating guidelines:

- | | |
|---|---|
| <ul style="list-style-type: none">  Before connecting the device to the electrical supply, ensure that the operating voltage stated on the power supply corresponds to the voltage supplied to the unit.  The functioning and operational safety of the instrument can only be maintained under the conditions specified in the specifications section of this manual.  If the instrument is moved from warm surroundings, condensate may form and interfere with the functioning of this instrument. In this event, wait until the temperature of the photometer equilibrates to the new temperature before putting it back into operation.  If there is any reason to assume that the product can no longer be employed without risk, it must be set aside and appropriately marked to prevent further use. | <ul style="list-style-type: none">  The safety of the user may be endangered if the instrument: <ul style="list-style-type: none"> • is visibly damaged • no longer operates as specified • has been damaged in transport  If you are in doubt, the product should be sent back to the factory.  The operator of this product must ensure that the following laws and guidelines are observed when using this product around dangerous substances: <ul style="list-style-type: none"> • EEC Directives • National Fire Protection Association • Safety data sheets of the chemical manufacturer  Maintenance, and repair work must only be carried out by PendoTECH |
|---|---|

Optical Safety

- ⚠️ **WARNING:** The photometer can emit light from $\approx 200 - 1100\text{nm}$. Hazardous UV and IR radiation are emitted from the unit. Never directly stare into the source/return ports on the photometer or the fiber optic cables, as this can cause eye damage. The viewer-related risk is dependent on how the users install and use the product.
- ⚠️ Ensure that both ends of the fiber optic cables (photometer and flow cell connections) are properly secured (firmly hand tight) before powering on the photometer.
- ⚠️ The photometer should always be powered off when handling the fiber optic cables. If you must handle the fibers when the unit is powered on, protective eyewear must be worn.
- ⚠️ In the event of product failure, do not attempt to open the unit or replace the LED. There are no user-serviceable parts.

This warning label shown below can be found on both the photometer and the fiber optic cables ends. Users should take precautions and safety measures for both UV and IR radiation:

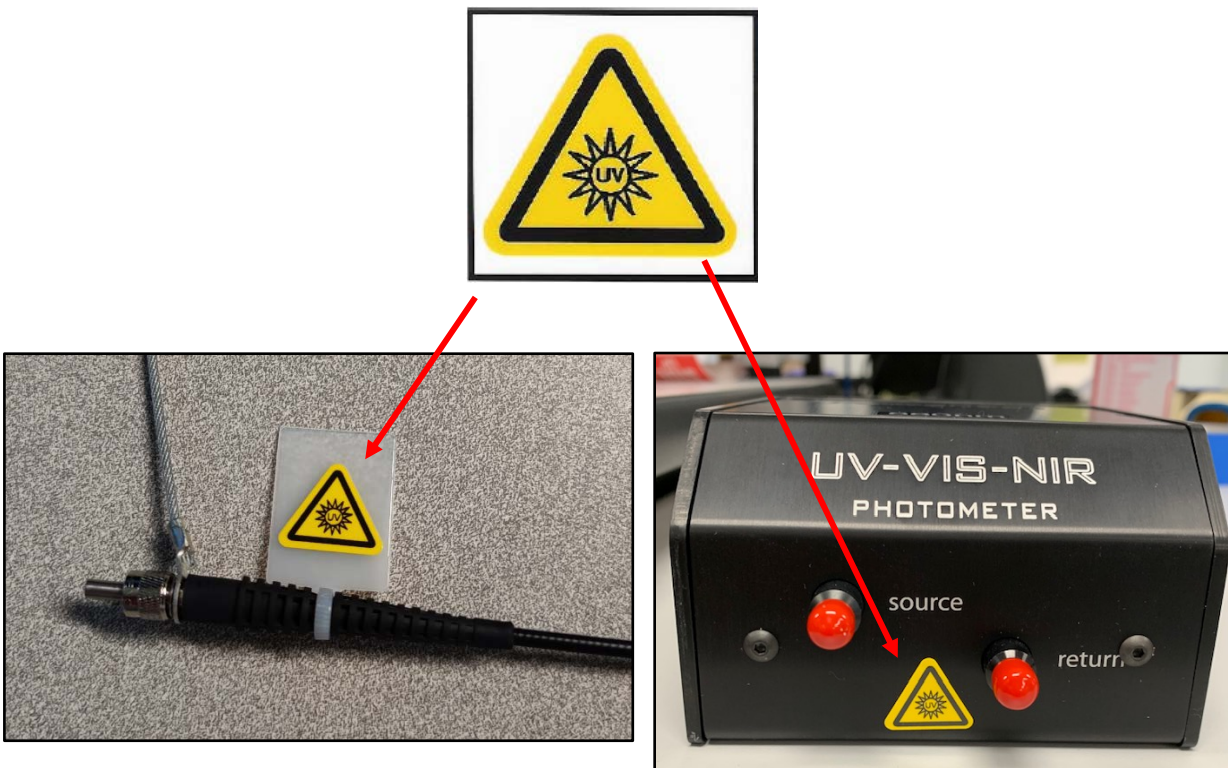



Notice of Confidentiality

The information contained within this document is confidential and proprietary to PendoTECH and may be covered under existing US patents or patents pending. This information shall not be reproduced or further disclosed, in whole or in part, to anyone other than employees of the company purchasing the product without prior written consent from PendoTECH.

Contents

Section 1: Introduction and Unpacking	6
Section 2: Hardware Installation	8
Section 4: Glossary and Definitions	16
Section 5: Instrument Controls	17
Section 6: Absorbance Operations	19
Section 7: System Specifications	20
Section 8: Appendix.....	21

Section 1: Introduction and Unpacking

PendoTECH's UV-VIS-NIR Photometer is a measuring and monitoring device that allows users to make in-line absorbance and turbidity measurements from bioprocess fluid streams. The photometer also acts as a transmitter with a 4-20mA output scaled 0-3 AU. The absorbance measurements are made by a collimated beam of light which passes through a sample with a defined path length. The absorbance is determined as the ratio of the light applied from the source to what passed through the sample. At wavelengths below 400nm, the photometer can be used to measure the UV absorbance of a liquid solution to identify the absence or presence of a molecule of interest. At wavelengths greater than 400nm, the photometer can be used to measure turbidity as an indication of filter performance or to measure unclarified material. The photometer also comes in a dual wavelength version, which allows users to make two measurements of different wavelengths (from 255 to 1000nm) simultaneously in the same sample.

The combination of the UV-VIS-NIR photometer and the PendoTECH Single Use Flow Cells allow the measurements to be made in-line. The flow cells contain a special silica glass lens and compartments to insert optical couplers which attach to the fiber optic cables from the photometer. The flow cells can also be used with PendoTECH's Flow Cell Stand with integral couplers in place of the optical couplers to connect the fiber optic cables. The flow cell stand is optional for UV absorbance applications, but it is highly recommended for turbidity applications because it blocks out ambient light that would otherwise affect the readings. Although they are designed for single use, the flow cells may be repeatedly cleaned and re-used.

Identify the following components:

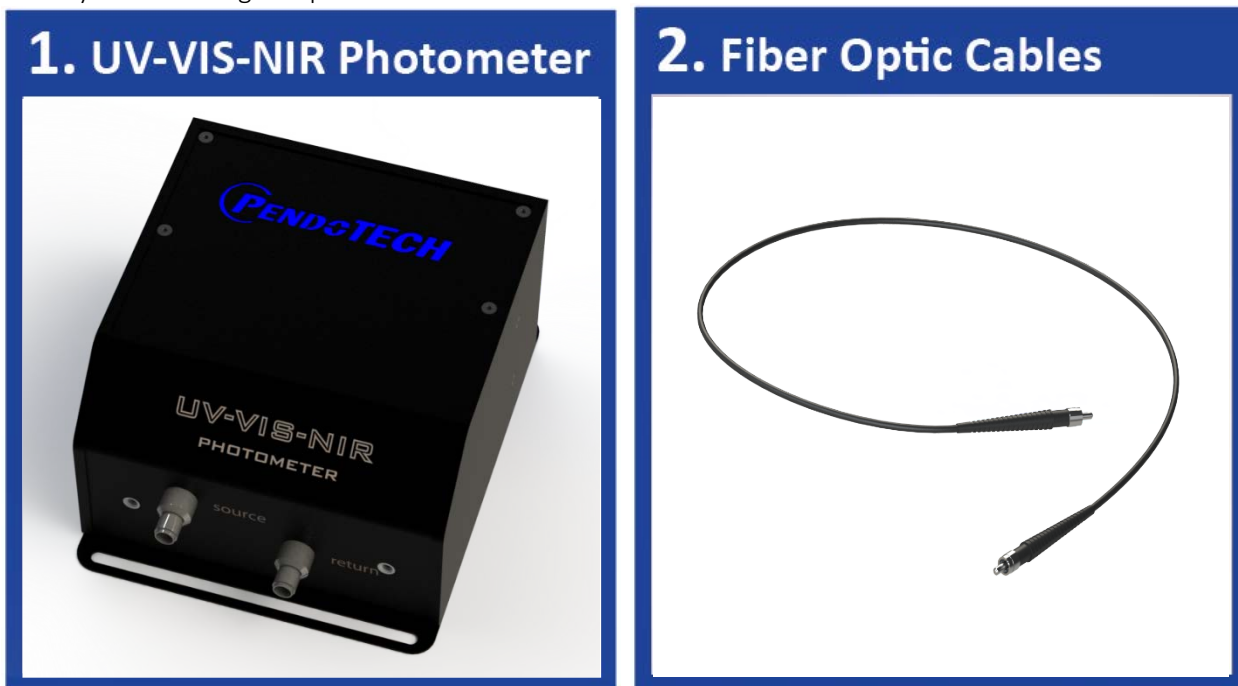

3. Optical Couplers/Flow Cell Holders (Varies per flow cell used and configuration type)



Optical Couplers Installed to Flow Cell

Flow Cell Stand Details

Stand features a compartment to place light filters for calibration verification

Removable cover with thumbwheel to secure to stand

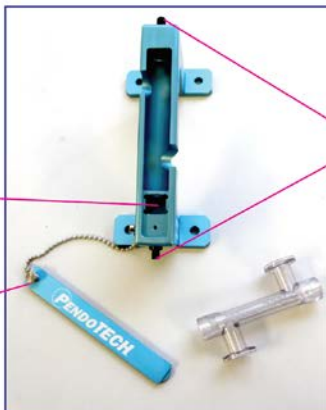

Flow Cell Stand for 6.5 cm flow cell
PART#: SPEC-FCH-L

SMA905 connectors for connection of fiber optics



Flow Cell Stand for 1 cm flow cell
PART#: SPEC-FCH-S

Optional Flow Cell Stand

4. Example Flow Cells:



Flow Cell with tubing installed

Single Use Flow Cell, 1cm path length

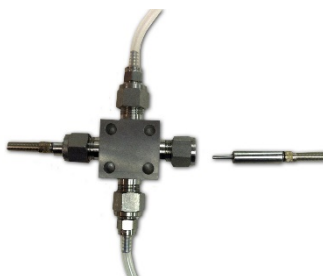

Adjustable Path Length Flow Cell,
coupler removed



Adjustable Path Length Flow Cell,
coupler inserted



6.5cm Single Use Turbidity Flow Cell

6.5 cm path length
with luer fitting for laboratory
studies



Section 2: Hardware Installation

Please follow the outlined sections below as a guideline for installing the photometer and associated accessories. These guidelines apply for specific application installations or in the case of OEM component installation onto a suitable panel.

DO NOT SUPPLY POWER TO THE UNIT UNTIL TOLD TO DO SO IN THE INSTRUMENT SETUP AND INITIALIZATION PROCEDURE IN SECTION 6.

2.1 Environmental

It is strongly recommended that the photometer be installed in a clean, dry area where ambient temperature does not exceed 115F/46C. Systems mounted in enclosures can be purged with clean, dry, oil-free air (or nitrogen) to dissipate heat within the enclosure.

2.2 Physical

For permanent installations, bolt the photometer, back panel, or enclosure (as appropriate) in place using mounting screws. The location should be secure, rigid, and strong enough to support the weight of the installed system.

For laboratory use, ensure that there is sufficient space on the bench or tabletop to accommodate the hardware supplied.

For all systems, run the fiber optic cable(s) through conduit or other appropriate protective measures as desired. Refer to Section 2.3 below for optical component installation instructions.

Run required electrical wiring for instrument power and output signals (4-20mA). Review Section 2.4 below prior to making electrical connections.

2.3 Optical



Photometer, front view

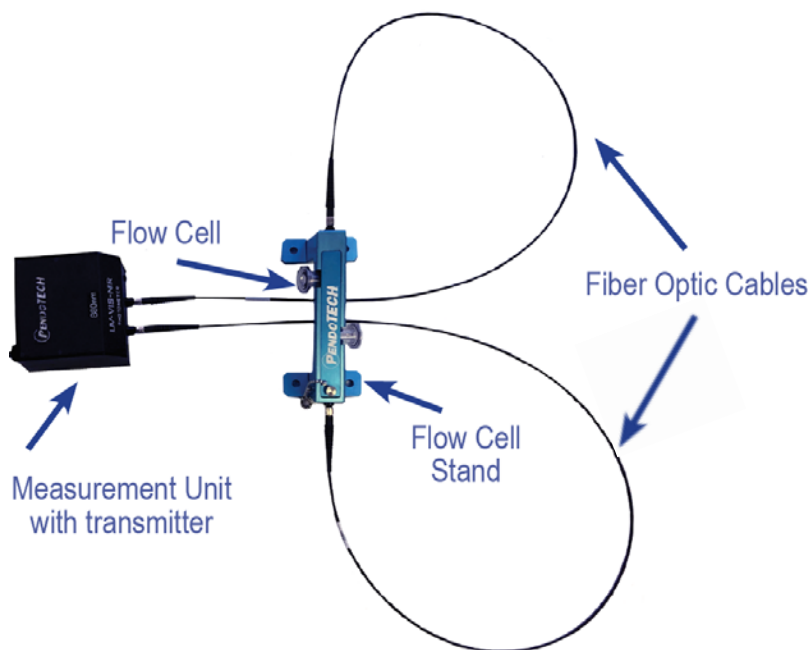

Complete system setup showing measure unit/photometer, flow cell stand/holder, and fiber optic cables

1. Remove the protective caps from the SMA-905 connectors on the fiber optic cables and the photometer.
2. Clean the fiber ends with spectroscopic-grade isopropyl alcohol (IPA, also known as 2-propanol) or methanol using a lint-free cotton swab or non-abrasive task wipe. Spectroscopic grade acetone can also be used, but separation of cotton from the swab might occur as the binding agent dissolves.
3. Properly mount the flow cell stand/holder (if applicable to system). The flow cell stand can be set directly flat on a lab bench, or should be properly wall/panel-mounted. Proper mounting of the flow cell stand facilitates the pass through of bubbles/air pockets in the fluid stream, which if trapped in the flow cell, can degrade system performance.

SPEC-FCH-L Panel Mounting	SPEC-FCH-S Panel Mounting
<p>Proper Orientation of Panel/Wall mount, 45 degree angle, outlet higher than inlet</p>	<p>Proper Orientation of Panel/Wall mount, vertical liquid travel, outlet above inlet</p>

4. Connect the flow cell with optical couplers or flow cell stand to the photometer with the fiber optic cables. It does not matter which fiber connects to the source and return.
NOTE: Ensure that both ends of the fiber optic cables (photometer and flow cell connections) are properly secured (firmly hand tight) before powering on the photometer.
5. Power on the unit. Refer to section 2.4 below.
6. Press the tare button (or perform dry contact closure over Tare/Zero +/- pins). This initiates the calibration and taring routine. The status light will turn green.
 - a. **Note:** For best results, the unit should be tared/calibrated with the process background fluid in the flow cell if possible. If not possible, then a tare/calibration with air in the flow cell may be used instead.
7. Wait at least 10 seconds for the taring and calibration routine to complete. The status light will turn back blue.
 - a. **Note:** In a panel mount installation, the status LED is not visible. It is recommended to integrate a 10s indication display on the user interface that the unit is not ready for use (do not change fluid state in the flow cells light path).
8. The unit is now ready for operation.

NOTE: The fiber optic cables must be secured so they are not free to move around, be stepped on, leaned against, or otherwise damaged during normal operations. The minimum bend radius for fibers supplied with the UV-VIS-NIR Photometer is 8" (20.3cm).

NOTE: Only hand tighten SMA-905 connections. Never use a wrench, pliers, or other tool. Over-tightening the SMA-905 connections may result in damage to the connector and the fiber optic cable, drastically reducing or prohibiting light transmission and requiring the replacement of the fiber optic cables.

2.4 Electrical

Panel mount version



Lab version



NOTE: DO NOT power up the unit during installation. Ensure that all electrical connections are made with un-energized wires. It is recommended that an ON/OFF switch be employed for panel mounting.

1. Connect the power and ground to the system.

For laboratory systems, a 24VDC power supply is provided (wall adapter with plug blades for global use).

For panel-mounted systems, a 13-position terminal block connector is provided. Use a small flathead screwdriver to loosen the screw and insert a **NON-ENERGIZED** 12-48VDC lead (with the end stripped so that the metal wire is exposed) to position 12, and tighten the screw to secure the lead. Repeat the same procedure for the securing the grounding lead to position 13.

2. Connect the 4-20mA output. For single channel units, only pins 1 and 2 are used. For dual channel units, pins 1 and 2 correspond to the photometer's first wavelength (lower) and pins 3 and 4 correspond to the second wavelength (higher).

For panel-mounted systems, a terminal strip is provided for electrical connectivity.

For lab version systems, a cable that connects to the **Signal I/O** terminal on the back of the photometer may be purchased. The cable that has flying leads that can be used to connect to the desired output and alarms (PN: PDKT-UV2-FL). The leads are as follows:

Yellow: Alarm-Out (-)

Orange: Alarm-Out (+)

Violet: Current Loop 2 (-) (If dual wavelength unit, higher wavelength value)

Green: Current Loop 2 (+) (If dual wavelength unit, higher wavelength value)

Brown: Current Loop 1 (-)

Blue: Current Loop 1 (+)

PendoTECH also has other pre-configured cables for connections to the PendoTECH PressureMAT® Plus monitors, PendoTECH Control Systems, and other PendoTECH products.

Section 3: Introduction to Absorbance Monitoring

3.1 Theory of Operation

Absorbance measures how much of an incident light is absorbed when it passes through a material. The intensity of light decreases exponentially with distance as light passes through the material, so transmittance can be determined by measuring the intensity of both the incident and transmitted light. The value for transmittance can then be used to calculate the absorbance of the sample.

The Beer-Lambert Law relates how absorbance is related to the concentration and the distance the light must travel through the sample (path length):

$$A = \epsilon c l$$

Where A is absorbance, ϵ is the extinction coefficient, c is the concentration of the solution (in mol/L), and l is the path length traveled by light through the sample (in cm).

3.2 LED-Based Absorbance

Light emitting diode (LED)-based photometers are a good choice when qualitative measurements are desired. Additionally, through the use of calibration standards and environmental control, an LED-based photometer is capable of quantitative determination of analyte concentration. When making quantitative measurements, it is critical that the LED-based photometer is accurately correlated to standard laboratory methods and solutions.

The LED provides a specific wavelength (or wavelengths for dual channel models) range for measurement, selected to coincide with analyte-specific molecular absorbance. The LED is located internal to the photometer and is specific to the application. Therefore, the UV-VIS-NIR photometer is a dedicated instrument for monitoring only one or two specific analytes of interest.

Shown below are three example LED spectrum profiles graphs, for typical LED light source wavelengths 260/280/880nm (Figures 1-3).

Definitions

- **CWL (Center Wavelength):** The wavelength of an optical source that is considered its' middle. The wavelength of the peak of the spectral density curve.
 - **Watch-Out:** If measurements are attempted on a shoulder/slope of the molecule's absorption profile, the absorption measurement can change dramatically over the span of a few nanometers. Absorbance may never saturate as a portion of the LED's output is outside of the molecule's absorbance profile. Minute photometer unit-to-unit absorption variations exist due to CWL tolerance.
- **FWHM (Full Width Half Maximum):** A measure of the range of light the LED generates. The width of an optical signal at half its maximum intensity

- **Watch-Out:** If the light source FWHM width is wider than the molecule's absorption peak, that will produce false, low absorption values.

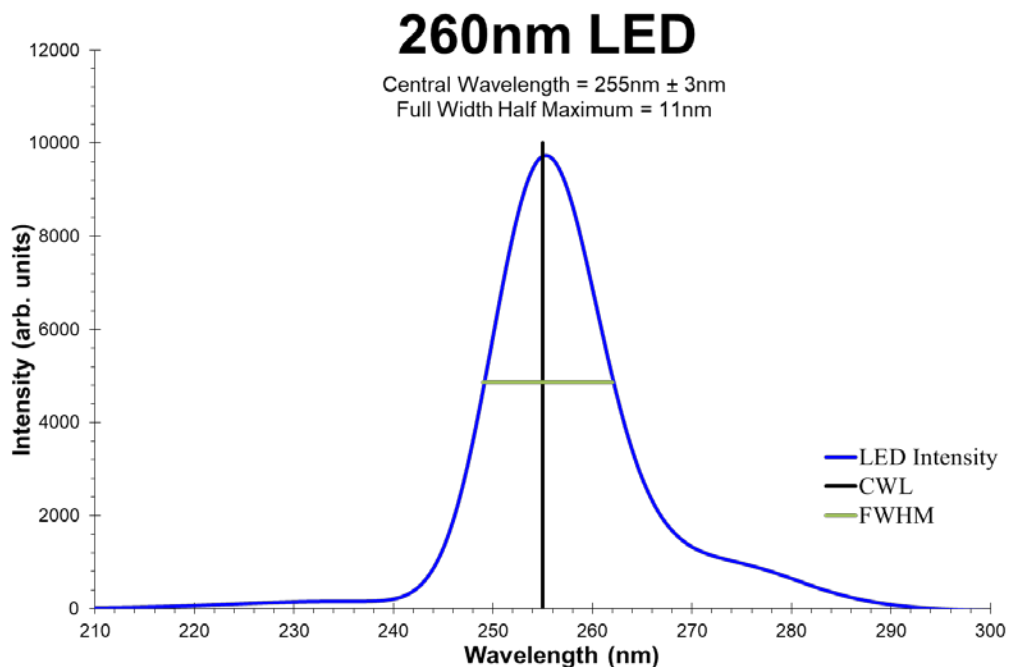

Figure 1 LED wavelength spectrum example for 260nm UV-VIS-NIR photometer.

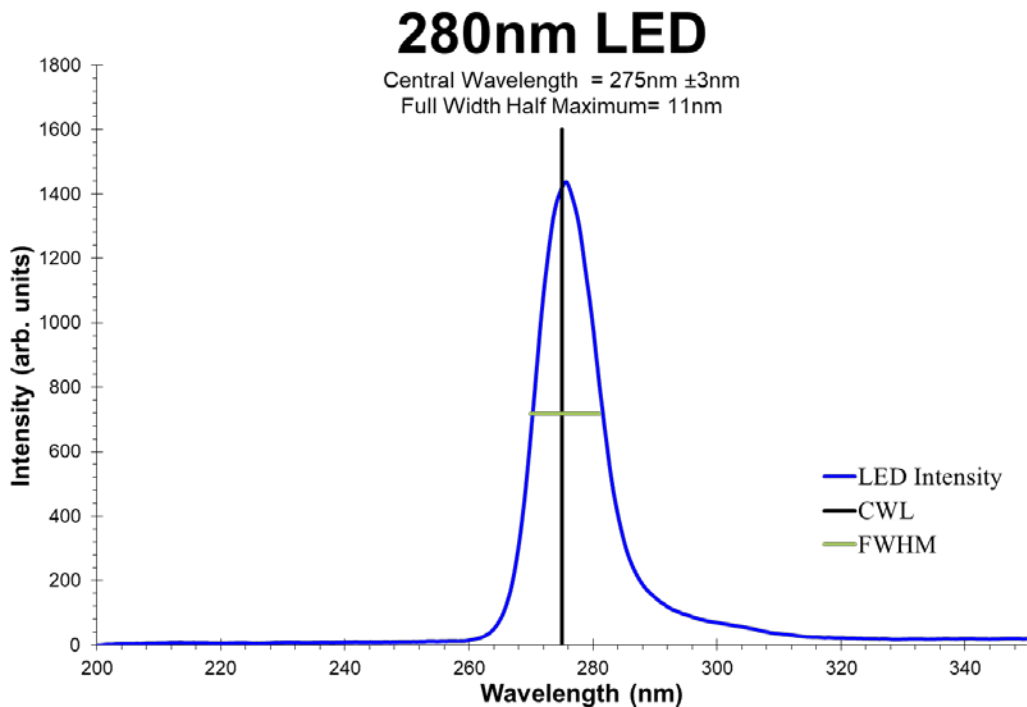

Figure 2 LED wavelength spectrum example for 280nm UV-VIS-NIR photometer.

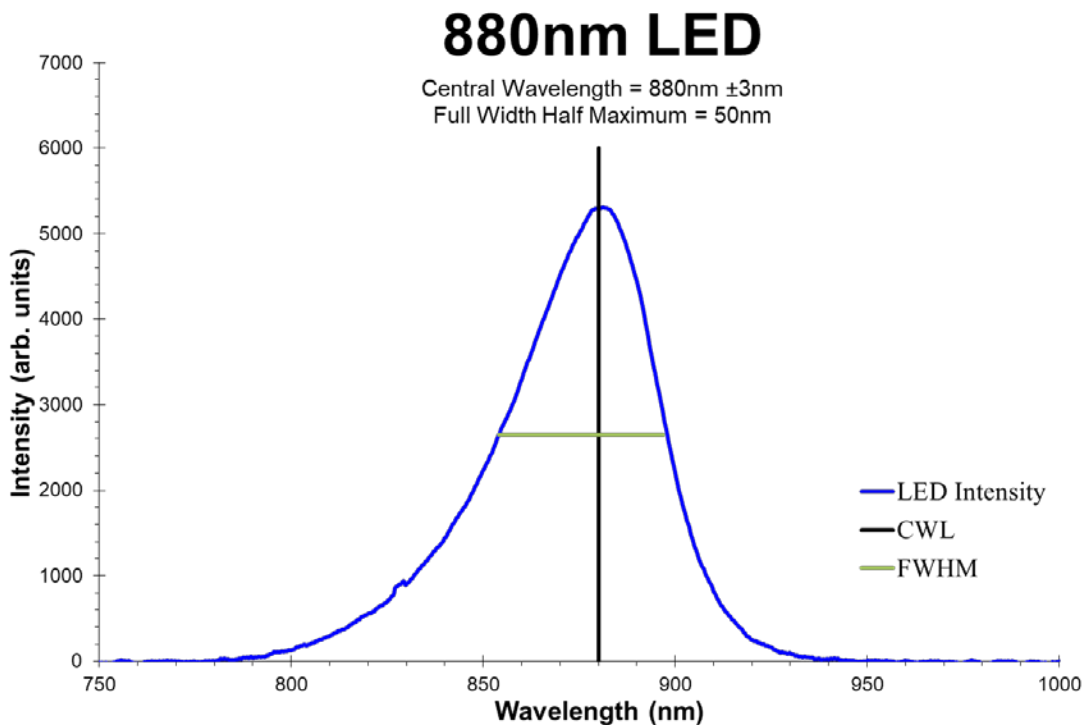

Figure 3 LED wavelength spectrum example for 880nm UV-VIS-NIR photometer.

In brief, the photometer works as follows: The measuring system is in the detector block of the photometer. Light is provided by an LED, which produces a stable light output at a narrow wavelength range. The reference signal is measured directly from the light source by the reference detector, and light that passes through the sample is measured by the measure detector. The reference channel is used in order to cancel variations from light source intensity fluctuations, spectral change due to window fouling, or suspended particles in the process stream.

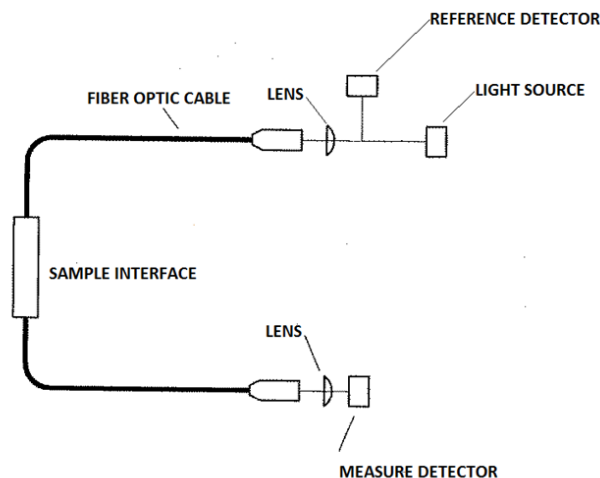

Figure 4 Optical diagram of photometer and flow cell sample interface

The remainder of this manual provides the user with the necessary tools to operate the photometer and meet the measurement requirements.

Section 4: Glossary and Definitions

Dynamic Range: Dynamic range refers to the range of concentrations an instrument can read, from the minimum to the maximum detectable concentration. The minimum detectable concentration is determined by the signal-to-noise ratio. The maximum detectable concentration is determined by the compound's chemistry and by factors such as instrument sensitivity ranges, optical pathlength, etc.

Linearity: Absorbance intensity is typically directly proportional (linear) to concentration. There are, however, many factors that affect this linear relationship. For example, stray light, turbidity, variation in chemical composition of the background, etc. can affect the linearity of the absorbance response.

Measure Detector: A detector that measures the intensity of light after it has contacted the sample. The system is designed in such a way that only absorbing wavelengths of light are measured by the measure detector.

Measure LED: The measure LED is the light emitting diode (LED) used to select the measurement wavelength.

Measure Wavelength: The wavelength, or range of wavelengths, of light that are absorbed by the analyte(s) of interest.

Process Background: The liquid or gas used to transport or sustain the analyte of interest in the process. This includes all the chemical constituents found in the process except the analyte of interest.

Reference LED: The reference LED is the light emitting diode (LED) used to select the reference wavelength to be measured by the reference detector. The center wavelength selected is a wavelength at which the analyte of interest does not absorb and is used to cancel variations from such effects as light source intensity fluctuations or spectral change due to window fouling or suspended particles in the process stream. Reference LED is an optional feature but is required for through media referencing.

Sensitivity: The ability of the photometer to detect a given level of analyte based on the molecular absorbance of the analyte. The actual limits of detection depend on the properties of the analyte measured and the process conditions.

Specificity: The ability of the analyzer to monitor one specific analyte in a mixture of background materials without interference from the background materials.

Section 5: Instrument Controls

5.1 Zero

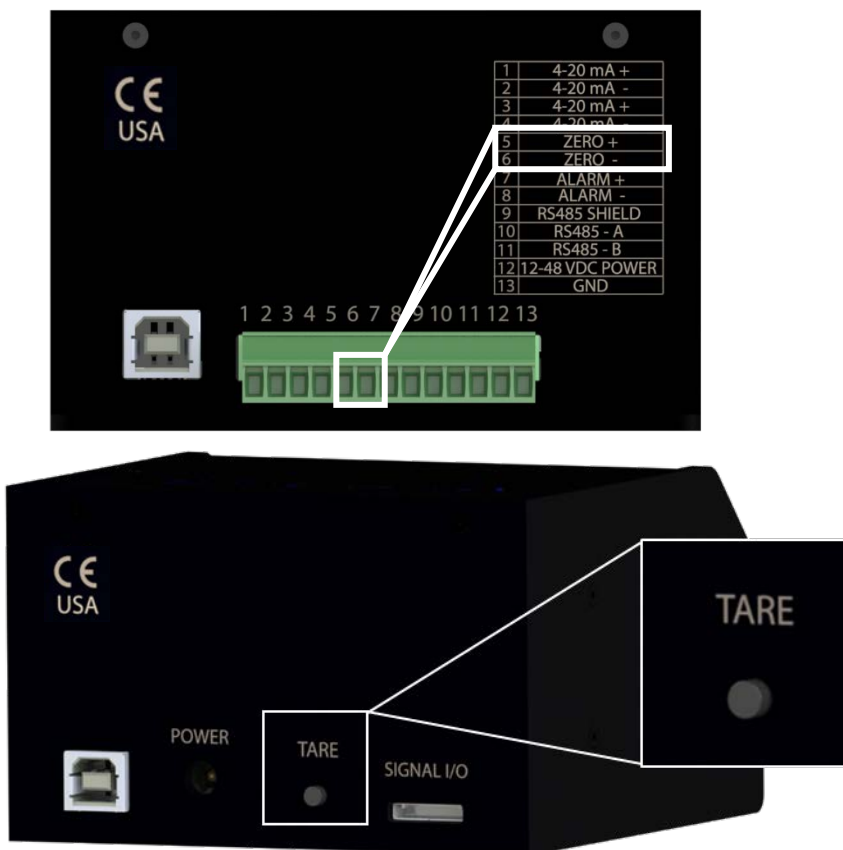

The zero button/contacts will set one (or both channels for dual wavelength model) to zero absorbance (0.00AU or 4.00mA).

NOTE: For best results, the unit should be tared/calibrated with the process background fluid in the flow cell if possible. If not possible, then a tare/calibration with air in the flow cell may be used instead.

5.2 Indicator LED

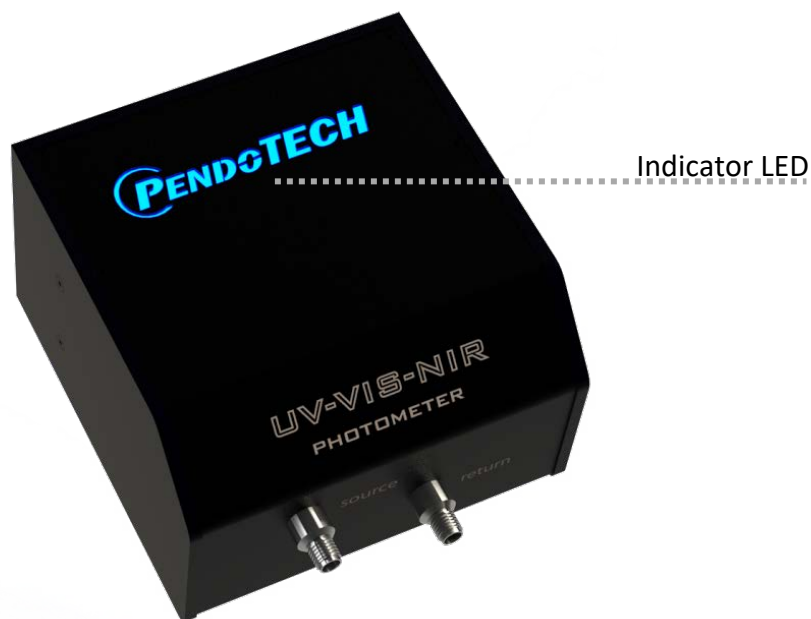

The indicator LED located on the top of the unit illuminates **BLUE** when the unit is making normal measurements, and **RED** when there is an issue with either the photometer or the flow cell.

5.3 Alarms

The photometer's indicator LED will glow **RED**, indicating an alarm condition. For panel mounted units, 2 dedicated alarm contact pins will close during an alarm. The alarm will activate if:

Alarm Activator	Cause	Solution
The measurement detector is saturated at 100%	Photometer outputting negative absorbance values due to bad tare	Re-tare flow cell with background solution or air
The reference detector is saturated at 100%	Extreme amount of ambient light entering flow cell/measure detector	Use flow cell holder to block ambient light from entering flow cell; ensure fiber optic cable connections are firmly hand tight
The reference light and dark signals are too close to each other	LED is dead	Send back to PendoTECH for repair

See Figure 1 for

Section 6: Absorbance Operations

NOTE: The 4-20mA output is correlated to absorbance intensity in AU (absorbance units). To convert absorbance intensity to relevant engineering units, the 4-20mA output must be scaled using an external device. The photometer cannot be set to relevant engineering units, and has a fixed range of 0.00-3.00AU = 4mA - 20mA.

NOTE: Please reference Section 2 for hardware installation instructions (environmental specifications, physical mounting, optical connectivity, and electrical connectivity).

This procedure assumes that the hardware has been installed correctly and is ready for operation. For panel-mounted systems, this procedure is valid once electrical connectivity is established.

DO NOT power the unit until directed to do so in this procedure.

1. Ensure that the fiber optic connections to the photometer and the corresponding optical flow cell couplers are hand tight. See **Section 2.3** for instructions
 - a. Insert single use flow cell into the flow cell stand/holder (if applicable). Replace the stand's cover, and tighten the cover's screw firmly to securely hold the flow ce..
2. Ensure that both the power and the analog output connections are wired correctly. See **Section 2.4** for instructions.
3. Provide power to the unit.
4. Zero (tare) the unit.
 - I. **For best results, the unit should be tared/calibrated with the process background fluid in the flow cell if possible. If not possible, then a tare/calibration with air in the flow cell may be used instead.**

Section 7: System Specifications

This section provides detailed specifications for the UV-VIS-NIR Photometer system purchased. In addition, this section may contain application specific notes on operability, functionality, etc.

7.1 Optical Configuration

The optical configuration listed is for a complete analyzer system. The detectors and light emitting diode (LED) are internal to the photometer housing.

Optical Method	Absorbance
Light Source	LED
Reference Selection	Internal Source Reference

7.2 Photometer Specifications

Configuration	Internal Source Reference
Optical Connectivity	SMA-905
Mechanical	4" (10.2cm) W x 4" (10.2cm) L x 2.5" (6.4cm) H Weight: ~1.5lbs.
Power Requirement	24VDC nominal, 2.7W max power
Output	4-20mA (Active/sourcing) spanned 0-3AU
Analog Loop Resistance	500 ohms at 24VDC
Operating Temperature	41to 122°F (5 to 50C)
Storage Temperature	-4 to 122°F (-20 to 50C)
Measurement Range	0.00-3.00AU
Response Time	1 second
Accuracy*	0-2AU: ±1%FS (±0.03AU) ; 2-3AU: ±2%FS (±0.06AU)
Precision/Repeatability	±0.5% full scale (±0.015AU)
LED Lifetime	> 5 years
Available Wavelengths	240-1000 nm
Regulatory	RoHS3, REACH, CE

*Accuracy is dependent on system arrangement and proper tare

When converting the 4-20mA output to Absorbance Units (AU):

Let x = 4-20mA output

$$\left(\frac{x - 4}{16}\right) \times 3.000 = AU$$

Section 8: Appendix

8.1 Drawings

Panel Mount Version (with mounting flange)

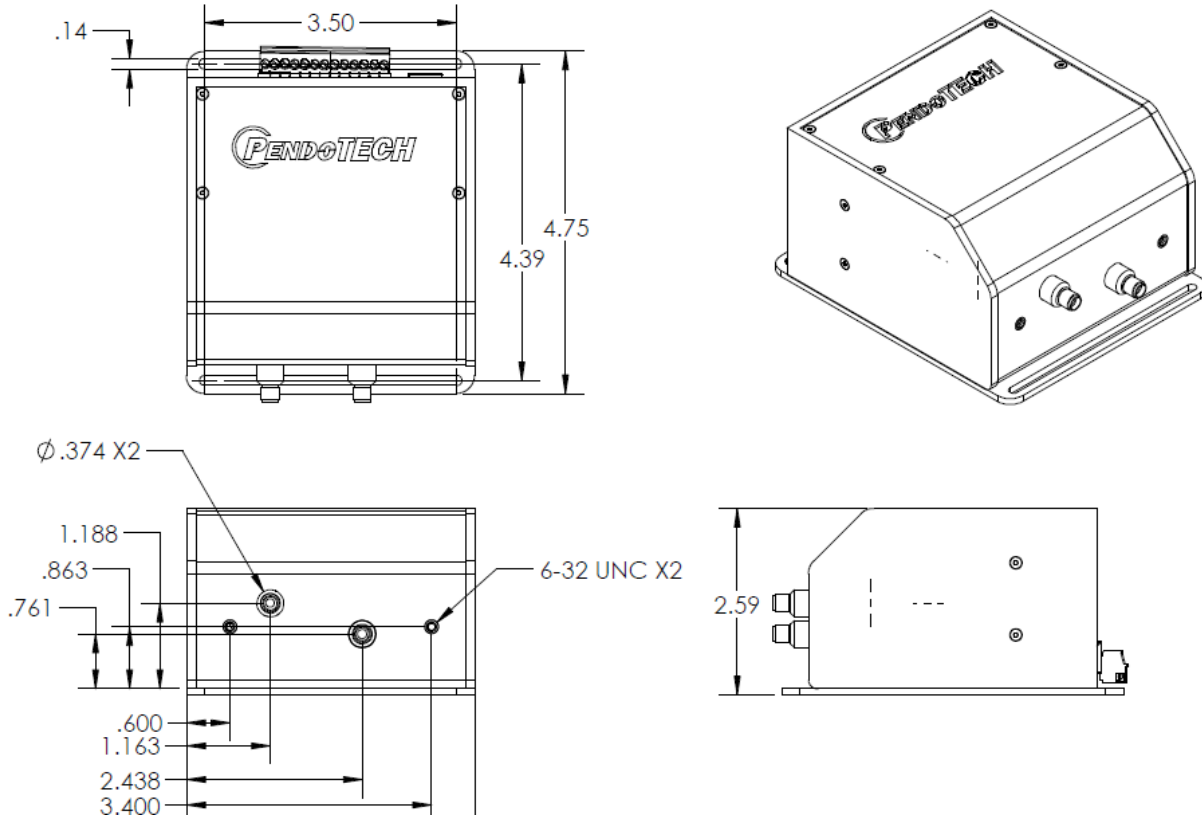

8.2 CE Certification

EC Declaration of Conformity

The undersigned, representing the following supplier:

PendoTECH
174 Nassau Street Suite 256
Princeton, NJ 08542 USA

Herewith declare that the	Information technology equipment devices for measurement, monitoring, controlling and communicating for commercial and light industrial application
Product Identification (brand models)	UV/VIS/NIR Photometer SPEC-P/L-1/2-SU/RU-XXX-YYY- PHOTO

are in conformity with the provisions of the following EC Directive(s) when installed in accordance with the instructions contained in supplied product documentation:

- 2014/30/EU EMC Directive, TUV Test Reports TP72129730.100 & TP72129730-000
- 2014/35/EU Low Voltage Directive, TUV Test Report TP72129730-000

and the standards and/or technical specifications for EN 61326-1: 2013 comprised on the following specifications:

CISPR 11, EN 61000-3-2, EN 61000-3-3, IEC 61000-4-2:2009, IEC 61000-4-3: 2006/A1:2008/A2:2010, IEC 61000-4-4: 2012, EN 61000-4-5 : 2006, EN 61000-4-6 : 2009, EN 55011 : 2010

Safety requirements for electrical equipment for measurement, control and laboratory use, Part 1: General Requirements; EN 61010-1:2010 3rd edition

Year of CE Marking: 2016 through Present

Supplier:

Signature On file
Name: James Furey
Position: General Manager
Date: October 2016



8.3 Product Warranty

PENDOTECH LIMITED WARRANTY

LIMITED WARRANTY: Subject to the limitations contained in LIMITATION OF REMEDY AND LIABILITY and except as otherwise expressly provided herein, PendoTECH LLC ("Seller") warrants that the Software will execute the programming instructions provided by Seller, and that the products, systems and goods ("Goods") manufactured by Seller will be free from defects in materials or workmanship under normal use and service until the expiration of twenty-four (24) months from the date of shipment by Seller. Expendable items are warranted to be free from defects in material and workmanship under normal use and service for a period of ninety (90) days from the date of shipment by Seller. Products purchased by Seller from a third party for resale to Buyer ("Resale Products") shall carry only the warranty extended by the original manufacturer. Buyer agrees that Seller has no liability for Resale Products beyond making a reasonable commercial effort to arrange for procurement and shipping of the Resale Products. If, within thirty (30) days after Buyer's discovery of any warranty defects during the applicable warranty period, Buyer notifies Seller thereof in writing, Seller shall, at its option and as Buyer's sole and exclusive remedy hereunder, promptly correct any errors that are found by Seller to exist in the Software, or repair or replace F.O.B. point of manufacture, that portion of the Goods or Software found by Seller to be defective. All replacements or repairs necessitated by inadequate preventive maintenance, or by normal wear and usage, or by fault of Buyer, or by unsuitable power sources or by attack or deterioration under unsuitable environmental conditions, or by abuse, accident, alteration, misuse, improper installation, modification, repair, storage or handling, or any other cause not the fault of Seller are not covered by this limited warranty, and shall be at Buyer's expense. Seller shall not be obligated to pay any costs or charges incurred by Buyer or any other party except as may be agreed upon in writing in advance by an authorized Seller representative. All costs of dismantling, reinstallation and freight and the time and expenses of Seller's personnel for site travel and diagnosis under this warranty clause shall be borne by Buyer unless accepted in writing by Seller. Failure by Buyer to give such written notice of defects within the applicable time period shall be deemed an absolute and unconditional waiver of Buyer's claim for such defects. Goods repaired and parts replaced during the warranty period shall be in warranty for the remainder of the original warranty period or ninety (90) days, whichever is longer. All warranties, either express or implied, extend to BUYER only. All descriptions, representations and/or other information concerning Goods on the PendoTECH website and/or contained in PendoTECH's advertisements, brochures, promotional material, or statements made by employees or sales representatives of PendoTECH are solely for general informational purposes only and are not binding upon PendoTECH. No employee or sales representative of PendoTECH shall have any authority to establish, expand or otherwise modify PendoTECH's warranty associated with the sale of Goods. SELLER shall not be liable to BUYER in any manner with respect to Goods sold. SELLER MAKES NO REPRESENTATIONS OR WARRANTIES OF ANY TYPE, EXPRESS OR IMPLIED, AND EXPRESSLY DISCLAIMS AND EXCLUDES ANY REPRESENTATION OR WARRANTY OF MERCHANTABILITY, FITNESS FOR A PARTICULAR PURPOSE OR USE, NON-INFRINGEMENT OR WARRANTY ARISING FROM USAGE OF TRADE, COURSE OF DEALING OR PERFORMANCE. PendoTECH, LLC makes no warranty or representation regarding whether or not a customer's end use of any PendoTECH product, system or good infringes the valid intellectual property rights of others.

LIMITATION OF REMEDY AND LIABILITY: SELLER SHALL NOT BE LIABLE FOR DAMAGES CAUSED BY DELAY IN PERFORMANCE. THE SOLE AND EXCLUSIVE REMEDY FOR BREACH OF WARRANTY HEREUNDER SHALL BE LIMITED TO REPAIR, CORRECTION OR REPLACEMENT UNDER THE LIMITED WARRANTY. IN NO EVENT, REGARDLESS OF THE FORM OF THE CLAIM OR CAUSE OF ACTION (WHETHER BASED IN CONTRACT, INFRINGEMENT, NEGLIGENCE, STRICT LIABILITY, OTHER TORT OR OTHERWISE), SHALL SELLER'S LIABILITY TO BUYER AND/OR ITS CUSTOMERS EXCEED THE PRICE TO BUYER OF THE SPECIFIC GOODS MANUFACTURED BY SELLER GIVING RISE TO THE CLAIM OR CAUSE OF ACTION. BUYER AGREES THAT IN NO EVENT SHALL SELLER'S LIABILITY TO BUYER AND/OR ITS CUSTOMERS EXTEND TO INCLUDE INCIDENTAL, CONSEQUENTIAL OR PUNITIVE DAMAGES. THE TERM "CONSEQUENTIAL DAMAGES" SHALL INCLUDE, BUT NOT BE LIMITED TO, LOSS OF ANTICIPATED PROFITS, LOSS OF USE, LOSS OF REVENUE AND COST OF CAPITAL.

Rev. 1

8.4 Service Information

Any product which is under warranty must be returned to PendoTECH for repair. If out of warranty, the user should call PendoTECH for over-the-phone assistance and our service staff will help determine if the unit should be returned for repair.

For factory service, please contact PendoTECH at request@pendotech.com or call +1-609-799-2299 for a return authorization number.

Then pack the unit carefully, preferably in the original shipping container, insure, and ship to PendoTECH.